

Genotyping of Renin Deficient (Renin 1c^{-/-}) Mice by PCR

Purpose: To identify the renin deficient mouse gene (renin 1c^{-/-}) from the C57BL/6 wild type mouse renin gene (renin 1c^{+/+}).

Gene Information: The mouse Renin gene is located on chromosome 1. It contains 9 exons and 8 introns encoding a protein of 402 amino acids (GenBank: AC068906). In renin^{-/-} mice, the renin gene has been disrupted by insertion of a neomycin (Neo) cassette sequence in replacement of exon 1-3, including ATG start codon. The cloning vector used in this deficient mouse is pMC1neo (GenBank no: U43611).

Target disruption of renin gene:

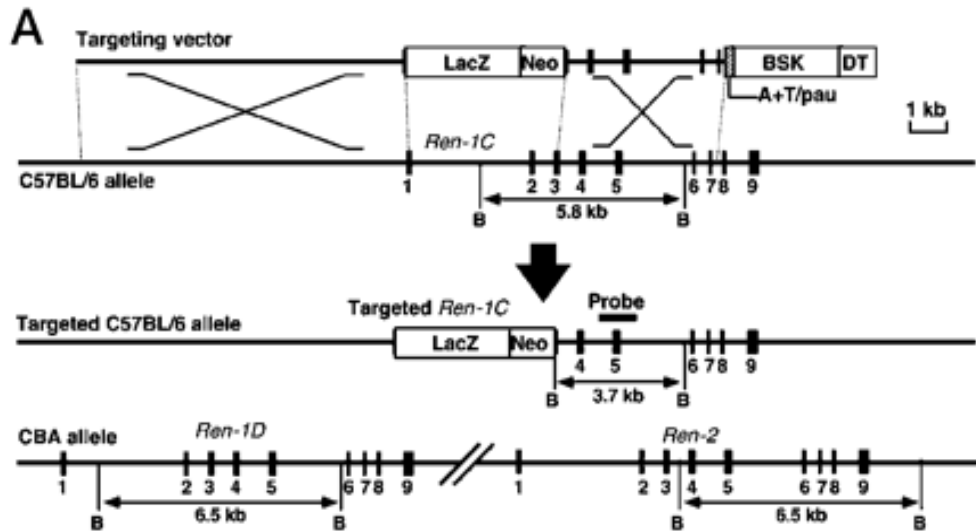

Primers:

Renin-F1 (exon 1) 5'-ACTCTTGTTGCTCTGGAGTCCTT-3' (position: 89067-89089)

Renin-R1 (intron 1) 5'-AGTAGTAGAAGGGGGAGTTGTGG-3' (position: 89331-89309)

NEO-F (neo gene) 5'-GCTACCCGTGATATTGCTGAA-3' (position: 1410-1430)

Renin-R2 (intron 3) 5'-CTTCCCAAAGCTGGCTTATTC-3' (position: 93412-93392)

PCR:

- Reaction
1. Genomic DNA (1 μ l)
 2. Promega PCR Master Mix (2x; 10 μ l)
 3. Primers (10 pmol/ μ l; 0.2 μ l each)
 4. Taq polymerase (0.1 μ l)
 5. PCR water (8.1 μ l)
- Total reaction volume is 20 μ l

- Program
1. 1 cycle - 94°C for 5 min
 2. 35 cycles - 94°C for 45 sec
56°C for 1 min
72°C for 1 min
 3. 1 cycle - 72°C 6 min
 4. Hold at 4°C.

Expected Bands on TBE Agarose Gel Electrophoresis:
on a 1.5% agarose gel.

renin +/+	265 bp
renin +/-	265 bp and 386 bp
renin -/-	386 bp

+/- +/+ -/-

Resolve DNA bands

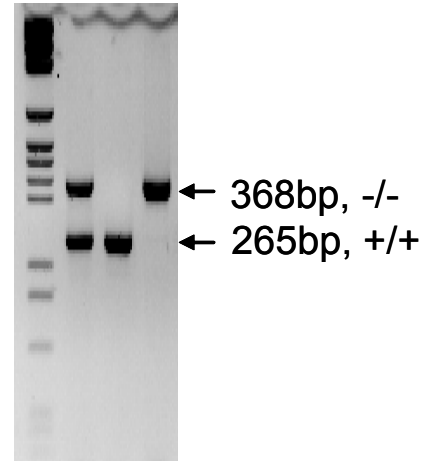

Screening Compound Deficient Mice:

This strategy will detect the renin alleles in compound deficient mice, as the primers are designed for the renin gene and the neomycin cassette.

Reference:

Yanai K et al. JBC 2000; 275(1): 5-8

File name: Z:\Protocols and forms\MOUSE\PCR protocols\renin genotyping.wpd

Date of last update: 11-16-06

Person prepared: Hong Lu

Daugherty Lab

University of Kentucky